

TITLE 35: ENVIRONMENTAL PROTECTION
SUBTITLE G: WASTE DISPOSAL
CHAPTER I: POLLUTION CONTROL BOARD
SUBCHAPTER b: PERMITS

PART 705
PROCEDURES FOR PERMIT ISSUANCE

SUBPART A: GENERAL PROVISIONS

Section	
705.101	Scope and Applicability
705.102	Definitions
705.103	Computation of Time
705.104	Electronic Reporting

SUBPART B: PERMIT APPLICATIONS

Section	
705.121	Permit Application
705.122	Completeness
705.123	Incomplete Applications
705.124	Site Visit
705.125	Effective Date
705.126	Decision Schedule
705.127	Consolidation of Permit Processing
705.128	Modification or Reissuance of Permits

SUBPART C: APPLICATION REVIEW

Section	
705.141	Draft Permits
705.142	Statement of Basis
705.143	Fact Sheet
705.144	Administrative Record for Draft Permits or Notices of Intent to Deny

SUBPART D: PUBLIC NOTICE

Section	
705.161	When Public Notice Must Be Given
705.162	Timing of Public Notice
705.163	Methods of Public Notice
705.164	Contents of Public Notice
705.165	Distribution of Other Materials

SUBPART E: PUBLIC COMMENT

Section	
705.181	Public Comments and Requests for Public Hearings
705.182	Public Hearings
705.183	Obligation to Raise Issues and Provide Information
705.184	Reopening of Public Comment Period

SUBPART F: PERMIT ISSUANCE

Section	
705.201	Final Permit Decision
705.202	Stay of Permit Conditions upon Appeal
705.203	Stay for New Application or upon Untimely Application for Renewal (Repealed)
705.204	Stay upon Reapplication or for Modification (Repealed)
705.205	Stay Following Interim Status (Repealed)
705.210	Agency Response to Comments
705.211	Administrative Record for Final Permits or Letters of Denial
705.212	Appeal of Agency Permit Determinations

SUBPART G: PROCEDURE FOR RCRA STANDARDIZED PERMIT

Section	
705.300	General Information About RCRA Standardized Permits
705.301	Applying for a RCRA Standardized Permit
705.302	Issuance of a RCRA Standardized Permit
705.303	Public Participation in the RCRA Standardized Permit Process
705.304	Modifying a RCRA Standardized Permit
705.APPENDIX A	Procedures for Permit Issuance
705.APPENDIX B	Modification Process
705.APPENDIX C	Application Process
705.APPENDIX D	Application Review Process
705.APPENDIX E	Public Comment Process
705.APPENDIX F	Permit Issuance or Denial

AUTHORITY: Implementing Sections 7.2, 13, and 22.4 and authorized by Section 27 of the Environmental Protection Act [415 ILCS 5/7.2, 13, 22.4 and 27].

SOURCE: Adopted in R81-32 at 6 Ill. Reg. 12479, effective May 17, 1982; amended in R82-19, at 7 Ill. Reg. 14352, effective May 17, 1982; amended in R84-9, at 9 Ill. Reg. 11894, effective July 24, 1985; amended in R89-2 at 14 Ill. Reg. 3082, effective February 20, 1990; amended in R94-5 at 18 Ill. Reg. 18265, effective December 20, 1994; amended in R95-6 at 19 Ill. Reg. 9906, effective June 27, 1995; amended in R03-7 at 27 Ill. Reg. 3675, effective February 14, 2003; amended in R06-16/R06-17/R06-18 at 31 Ill. Reg. 706, effective December 20, 2006; amended in R11-14 at 36 Ill. Reg. 1653, effective January 20, 2012; amended in R17-14/R17-15/R18-12/R18-31 at 42 Ill. Reg. 21179, effective November 19, 2018.

SUBPART A: GENERAL PROVISIONS

Section 705.101 Scope and Applicability

- a) This Part sets forth procedures that the Illinois Environmental Protection Agency (Agency) must follow in issuing RCRA (Resource Conservation and Recovery Act) and UIC (Underground Injection Control) permits. This Part also specifies rules on effective dates of permits and stays of contested permit conditions.
- b) This Part provides for a public comment period and a hearing in some cases. The permit applicant and any other participants must raise issues during this proceeding to preserve issues for effective Board review, as required by Section 705.183.
- c) Board review of permit issuance or denial is pursuant to 35 Ill. Adm. Code 105. Board review is restricted to the record that was before the Agency when the permit was issued, as required by Sections 40(a) and 40(b) of the Environmental Protection Act.
- d) The provisions of 35 Ill. Adm. Code 702, 703, and 704 contain rules on UIC and RCRA permit applications, permit conditions, and related matters.

(Source: Amended at 42 Ill. Reg. 21179, effective November 19, 2018)

Section 705.102 Definitions

The definitions in 35 Ill. Adm. Code 702 apply to this Part.

BOARD NOTE: Derived from 40 CFR 124.2 (2002).

(Source: Amended at 27 Ill. Reg. 3675, effective February 14, 2003)

Section 705.103 Computation of Time

Any time period allowance schedule or requirement provided under this Part must be computed in accordance with 35 Ill. Adm. Code 101.300.

BOARD NOTE: This Section corresponds with 40 CFR 124.20 (2002).

(Source: Amended at 27 Ill. Reg. 3675, effective February 14, 2003)

Section 705.104 Electronic Reporting

The filing of any document pursuant to any provision of this Part as an electronic document is subject to 35 Ill. Adm. Code 720.104.

BOARD NOTE: Derived from 40 CFR 3 and 145.11(a)(33), as added, and 40 CFR 271.10(b), 271.11(b), and 271.12(h) (2005), as amended at 70 Fed. Reg. 59848 (Oct. 13, 2005).

(Source: Added at 31 Ill. Reg. 706, effective December 20, 2006)

SUBPART B: PERMIT APPLICATIONS

Section 705.121 Permit Application

- a) Any person who requires a permit under the RCRA (Resource Conservation and Recovery Act) or UIC (Underground Injection Control) program must complete, sign, and submit to the Agency an application for each permit required under 35 Ill. Adm. Code 703.121 or 35 Ill. Adm. Code 704.101 through 704.105, as appropriate. An application will not be required for a RCRA permit by rule under 35 Ill. Adm. Code 703.141. An application will not be required for underground injection authorized by rule under Subpart C of 35 Ill. Adm. Code 704.
- b) The Agency must not begin the processing of a permit until the applicant has fully complied with the application requirements applicable to that type of permit.
- c) Permit applications must comply with the signature and certification requirements of 35 Ill. Adm. Code 702.126.

BOARD NOTE: Derived from 40 CFR 124.3(a) (2002).

(Source: Amended at 27 Ill. Reg. 3675, effective February 14, 2003)

Section 705.122 Completeness

- a) The Agency must review every application for a RCRA or UIC permit for completeness.
- b) Time limitations on Agency review for application completeness:
 - 1) Each application for a permit submitted by a new HWM (hazardous waste management) facility or new UIC injection well must be reviewed for completeness within 30 days of its receipt.
 - 2) Each application for a permit by an existing HWM facility (both Parts A and B of the application) or existing injection well must be reviewed for completeness within 60 days of receipt.
- c) Upon completing its review for completeness, the Agency must notify the applicant in writing whether the application is complete. If the application is incomplete, the Agency must list the information necessary to make the application complete.
- d) When the application is for an existing HWM (Hazardous Waste Management) facility or an existing UIC injection well, the Agency must also specify in the notice of deficiency a date for submitting the necessary information.

- e) The Agency shall, within the time limitations specified in subsection (b), notify the applicant whether additional information submitted in response to a notice of deficiency is deemed sufficient or insufficient to complete the application.
- f) After the application is deemed complete, the Agency may request additional information from an applicant only when necessary to clarify, modify, or supplement previously submitted material. Requests for such additional information will not render an application incomplete.

BOARD NOTE: Derived from 40 CFR 124.3(c) (2017).

(Source: Amended at 42 Ill. Reg. 21179, effective November 19, 2018)

Section 705.123 Incomplete Applications

If an applicant fails or refuses to correct Agency-noted deficiencies in its permit application, the Agency may either deny or issue the permit on the basis of the information available to the Agency; if warranted, appropriate enforcement actions may be taken.

BOARD NOTE: Derived from 40 CFR 124.3(d) (2002).

(Source: Amended at 27 Ill. Reg. 3675, effective February 14, 2003)

Section 705.124 Site Visit

If the Agency decides, pursuant to Section 4(d) of the Act, that a site visit is necessary for any reason in conjunction with the processing of an application, the Agency must notify the applicant, and the Agency and the applicant must schedule a site visit.

BOARD NOTE: Derived from 40 CFR 124.3(e) (2002).

(Source: Amended at 27 Ill. Reg. 3675, effective February 14, 2003)

Section 705.125 Effective Date

The effective date of a permit application is the date on which the Agency notifies the applicant that the application is complete, as provided in Section 705.122.

BOARD NOTE: Derived from 40 CFR 124.3(f) (2002).

(Source: Amended at 27 Ill. Reg. 3675, effective February 14, 2003)

Section 705.126 Decision Schedule

For each permit application from a major new HWM facility or major new UIC injection well, the Agency must, no later than the effective date of the application, prepare and mail to the applicant a projected decision schedule. The schedule must specify target dates by which the Agency intends to do the following:

- a) Prepare a draft permit pursuant to Subpart C;
- b) Give public notice pursuant to Subpart D;
- c) Complete the public comment period, including any public hearing pursuant to Subpart E; and
- d) Issue a final permit pursuant to Subpart F.

BOARD NOTE: Derived from 40 CFR 124.3(g) (2017).

(Source: Amended at 42 Ill. Reg. 21179, effective November 19, 2018)

Section 705.127 Consolidation of Permit Processing

Whenever a facility or activity requires more than one permit under more than one Part of the Board's rules and regulations, processing of two or more applications for those permits the Agency may, in its discretion and consistent the individual requirements for each permit, consolidate the processing of those permit applications in accordance with Agency procedures.

BOARD NOTE: Derived from 40 CFR 124.4 (2002).

(Source: Amended at 27 Ill. Reg. 3675, effective February 14, 2003)

Section 705.128 Modification or Reissuance of Permits

- a) The Agency may modify or reissue a permit either at the request of any interested person (including the permittee) or on its own initiative. However, the Agency may only modify or reissue a permit for the reasons specified in 35 Ill. Adm. Code 704.261 through 704.263 (UIC) or 35 Ill. Adm. Code 703.270 through 703.273 (RCRA). A request for permit modification or reissuance must be made in writing, must be addressed to the Agency (Division of Land Pollution Control), and must contain facts or reasons supporting the request.
- b) If the Agency determines that a request for modification or reissuance is not justified, it must send the requester a brief written response giving a reason for the determination. A denial of a request for modification or reissuance is not subject to public notice, comment, or public hearing requirements. The requester may appeal a denial of a request to modify or reissue a permit to the Board pursuant to 35 Ill. Adm. Code 105.
- c) Agency Modification or Reissuance Procedures
 - 1) If the Agency tentatively decides to initiate steps to modify or reissue a permit pursuant to this Section and 35 Ill. Adm. Code 704.261 through 704.263 or 35 Ill. Adm. Code 703.270 through 703.273 (other than 35 Ill. Adm. Code 703.272(c)), after giving public notice pursuant to Section 705.161(a)(1), as though an application had been received, it must prepare a

draft permit pursuant to Section 705.141 incorporating the proposed changes. The Agency may request additional information and may require the submission of an updated permit application. For reissued permits, other than those reissued under 35 Ill. Adm. Code 703.272(c), the Agency must require the submission of a new application. For permits reissued under 35 Ill. Adm. Code 703.272(c), the Agency and the permittee must comply with the appropriate requirements in Subpart G of 35 Ill. Adm. Code 705.

- 2) In a permit modification proceeding pursuant to this Section, only those conditions to be modified must be reopened when a new draft permit is prepared. When a permit is to be reissued pursuant to this Section, the entire permit is reopened just as if it had expired. During any reissuance proceeding, including any appeal to the Board, the permittee must comply with all conditions of its existing permit until a new final permit is reissued.
- 3) “Minor modifications”, as defined in 35 Ill. Adm. Code 704.264, and “Class 1 and 2 modifications”, as defined in 35 Ill. Adm. Code 703.281 and 703.282, are not subject to this Section.
- d) To the extent that the Agency has authority to reissue a permit, it must prepare a draft permit or notice of intent to deny in accordance with Section 705.141 if it decides to do so.
- e) The Agency or any person may seek the revocation of a permit in accordance with Title VIII of the Environmental Protection Act and the procedure of 35 Ill. Adm. Code 103. Revocation may only be sought for those reasons specified in 35 Ill. Adm. Code 702.186(a) through (d).

BOARD NOTE: Derived from 40 CFR 124.5 (2017).

(Source: Amended at 42 Ill. Reg. 21179, effective November 19, 2018)

SUBPART C: APPLICATION REVIEW

Section 705.141 Draft Permits

- a) Once an application for permit is complete, the Agency must tentatively decide whether to prepare a draft permit or to deny the application.
- b) If the Agency tentatively decides to deny the permit application, it must issue a notice of intent to deny. A notice of intent to deny must be subject to all of the procedural requirements applicable to draft permits under subsection (d). If the Agency’s final decision made pursuant to Section 705.201 is that the tentative decision to deny the permit application was incorrect, it must withdraw the notice of intent to deny and proceed to prepare a draft permit under subsection (c).
- c) If the Agency decides to prepare a draft permit, it must prepare a draft permit that contains the following information:

- 1) All conditions under 35 Ill. Adm. Code 702.140 through 702.152 and 35 Ill. Adm. Code 702.160;
 - 2) All compliance schedules under 35 Ill. Adm. Code 702.162 and 702.163;
 - 3) All monitoring requirements under 35 Ill. Adm. Code 702.164; and
 - 4) The following program-specific permit conditions:
 - A) For RCRA permits, standards for treatment, storage, or disposal and other permit conditions under Subpart F of 35 Ill. Adm. Code 703;
 - B) For UIC permits, permit conditions under Subpart E of 35 Ill. Adm. Code 704.
- d) A draft permit or a notice of intent to deny prepared under this Section must be accompanied by a statement of basis, under Section 705.142, or a fact sheet, under Section 705.143, must be based on the administrative record pursuant to Section 705.144, must be publicly noticed pursuant to Subpart D, and must be made available for public comment pursuant to Section 705.181. The Agency must give notice of opportunity for a public hearing pursuant to Section 705.182, issue a final decision pursuant to Section 705.201, and respond to comments pursuant to Section 705.210. An appeal may be taken under Section 705.212.

BOARD NOTE: Derived from 40 CFR 124.6 (2017).

(Source: Amended at 42 Ill. Reg. 21179, effective November 19, 2018)

Section 705.142 Statement of Basis

The Agency must prepare a statement of basis for every draft permit or notice of intent to deny for which a fact sheet under Section 705.143 is not prepared. The statement of basis must briefly describe the derivation of the conditions of the draft permit and the reasons for them or, in the case of notices of intent to deny, reasons supporting the tentative decision. The statement of basis must be sent to the applicant and to any other person who requests it.

BOARD NOTE: Derived from 40 CFR 124.7 (2002).

(Source: Amended at 27 Ill. Reg. 3675, effective February 14, 2003)

Section 705.143 Fact Sheet

- a) A fact sheet must be prepared for every draft permit for a major HWM or a major UIC facility or activity, and for every draft permit or notice of intent to deny that the Agency finds is the subject of widespread public interest or raises major issues. The fact sheet must briefly set forth the principal facts and the significant factual, legal, methodological, and policy questions considered in preparing the draft permit. The

Agency must send this fact sheet to the applicant and, on request, to any other person.

- b) The fact sheet must include the following, when applicable:
 - 1) A brief description of the type of facility or activity that is the subject of the draft permit;
 - 2) The type and quantity of wastes, fluids or pollutants that are proposed to be or are being treated, stored, disposed of, injected, emitted, or discharged;
 - 3) A brief summary of the basis for refusing to grant a permit or for imposing each draft permit condition including references to applicable statutory or regulatory provisions and appropriate supporting references to the administrative record as defined by Section 705.144;
 - 4) Reasons why any requested schedules of compliance or other alternatives to required standards do or do not appear justified;
 - 5) A description of the procedures for reaching a final decision on the draft permit including the following:
 - A) The beginning and ending dates of the comment period pursuant to Subpart D, and the address where comments will be received;
 - B) Procedures for requesting a hearing, and the nature of that hearing; and
 - C) Any other procedures by which the public may participate in the final decision.
 - 6) The name and telephone number of a person to contact for additional information.

BOARD NOTE: Derived from 40 CFR 124.8 (2017).

(Source: Amended at 42 Ill. Reg. 21179, effective November 19, 2018)

Section 705.144 Administrative Record for Draft Permits or Notices of Intent to Deny

- a) The provisions of a draft permit or notice of intent to deny the application must be based on the administrative record, as defined in this Section.
- b) The administrative record must consist of the following:
 - 1) The application and any supporting data furnished by the applicant;
 - 2) The draft permit or notice of intent to deny the application;

- 3) The statement of basis, as provided in Section 705.142, or fact sheet, as provided in Section 705.143;
 - 4) All documents cited in the statement of basis or fact sheet;
 - 5) Other documents contained in the supporting file for the draft permit or notice of intent to deny; and
 - 6) An index of all documents or items included in the record, by location in the record.
- c) Published material that is generally available, and which is included in the administrative record under subsection (b), need not be physically included with the rest of the record, as long as it is specifically referred to in the statement of basis or the fact sheet.
- d) This Section applies to all draft permits or notices of intent to deny.

BOARD NOTE: Derived from 40 CFR 124.9 (2017).

(Source: Amended at 42 Ill. Reg. 21179, effective November 19, 2018)

SUBPART D: PUBLIC NOTICE

Section 705.161 When Public Notice Must Be Given

- a) The Agency must give public notice whenever any of the following actions have occurred:
- 1) A permit application has been tentatively denied under Section 705.141(b);
 - 2) A draft permit has been prepared under Section 705.141(c); and
 - 3) A hearing has been scheduled under Section 705.182.
- b) No public notice is required when a request for permit modification or reissuance is denied under Section 705.128(b). Written notice of any such denial must be given to the requester and to the permittee.
- c) A public notice may describe more than one permit or permit action.

BOARD NOTE: Derived from 40 CFR 124.10(a) (2002).

(Source: Amended at 27 Ill. Reg. 3675, effective February 14, 2003)

Section 705.162 Timing of Public Notice

- a) Public notice of the preparation of a draft permit (including a notice of intent to deny a permit application) required under Section 705.161 must allow time for public comment, as follows:
 - 1) For UIC permits, at least 30 days; or
 - 2) For RCRA permits, at least 45 days.
- b) Public notice of a public hearing must be given at least 30 days in advance of the hearing.
- c) Public notice of a hearing may be given at the same time as public notice of the draft permit, and the two notices may be combined.

BOARD NOTE: Derived from 40 CFR 124.10(b) (2002).

(Source: Amended at 27 Ill. Reg. 3675, effective February 14, 2003)

Section 705.163 Methods of Public Notice

Public notice of activities described in Section 705.161(a) must be given by the following methods:

- a) By mailing a copy of a notice to the following persons (any person otherwise entitled to receive notice under this paragraph may waive his or her rights to receive notice for any classes and categories of permits):
 - 1) The applicant.
 - 2) Any other agency or entity that the Agency knows is required by State or federal law to review or approve issuance of a RCRA or UIC permit for the same facility or activity (including USEPA, other Federal and State agencies with jurisdiction over waterways, wildlife or other natural resources, and other appropriate government authorities, including other affected States and units of local government).
 - 3) Federal and State agencies with jurisdiction over fish, shellfish and wildlife resources and over coastal zone management plans, the Advisory Council on Historical Preservation, State Historic Preservation Officers, and other appropriate government authorities, including any affected States.
 - 4) Persons on a mailing list developed by doing as follows:
 - A) Including those who request in writing to be on the list;
 - B) Including participants in past permit proceedings in that area; and

- C) Notifying the public of the opportunity to be put on the mailing list through periodic publication in the public press and in governmental publications.
 - D) The Agency may update the mailing list from time to time by requesting written indication of continued interest from those listed. The Agency may delete from the list the name of any person who fails to respond to such a request.
- 5) For RCRA permits only to the following entities:
- A) To any unit of local government having jurisdiction over the area where the facility is proposed to be located; and
 - B) To each State agency having any authority under State law with respect to the construction or operation of such facility.
- 6) For Class I injection well UIC permits only, to the Illinois Department of Natural Resources, Office of Mines and Minerals.
- 7) For a Class VI injection well, mailing or e-mailing a notice to the Illinois Department of Natural Resources, Office of Mines and Minerals, Division of Gas and Oil and to the Agency, Divisions of Public Water Supply and Land Pollution Control.
- 8) Any other person or entity that the Agency has reason to believe would be particularly interested in or affected by the proposed action.
- b) Publication of notice must be made as follows:
- 1) For major UIC permits, publication of a notice in a daily or weekly newspaper of general circulation within the area affected by the facility or activity.
 - 2) For RCRA permits, publication of a notice in a daily or weekly major local newspaper of general circulation and broadcast over local radio stations.
- c) Any other method reasonably calculated to give actual notice of the action in question to the persons potentially affected by it.

BOARD NOTE: Derived from 40 CFR 124.10(c) (2011).

(Source: Amended at 36 Ill. Reg. 1653, January 20, 2012)

Section 705.164 Contents of Public Notice

- a) All public notices issued under this Part must contain the following minimum information:

- 1) The name and address of the Agency;
 - 2) The name and address of the permittee or permit applicant and, if different, the name and address of the facility or activity regulated by the permit;
 - 3) A brief description of the business conducted at the facility or the activity described in the permit application or the draft permit;
 - 4) The name, address, and telephone number of a person from whom interested persons may obtain further information, including copies of the draft permit; a copy of the statement of basis or fact sheet; and a copy of the permit application;
 - 5) A brief description of the comment procedures required by Sections 705.181 and 705.182; the time and place of any hearing that will be held, including a statement of the procedures to request a hearing (unless a hearing has already been scheduled); and the other procedures by which the public may participate in the final permit decision;
 - 6) The location of the administrative record required by Section 705.144, the time at which the record will be open for public inspection, and a statement that all data submitted by the applicant is available as part of the administrative record; and
 - 7) Any additional information that the Agency considers necessary or appropriate.
- b) Public Notices for Hearings. In addition to the general public notice described in subsection (a), the public notice of a hearing under Section 705.182 must contain the following information:
- 1) Reference to the date of previous public notices relating to the permit;
 - 2) The date, time, and place of the hearing; and
 - 3) A brief description of the nature and purpose of the hearing, including the applicable rules and procedures.

BOARD NOTE: Derived from 40 CFR 124.10(d) (2017).

(Source: Amended at 42 Ill. Reg. 21179, effective November 19, 2018)

Section 705.165 Distribution of Other Materials

In addition to the general public notice described in Section 705.164(a), all persons identified in Section 705.163(a) must be mailed a copy of the fact sheet or statement of basis, the permit application (if any), and the draft permit (if any).

BOARD NOTE: Derived from 40 CFR 124.10(e) (2002).

(Source: Amended at 27 Ill. Reg. 3675, effective February 14, 2003)

SUBPART E: PUBLIC COMMENT

Section 705.181 Public Comments and Requests for Public Hearings

During the public comment period provided under Subpart D, any interested person may submit written comments on the draft permit to the Agency, and any interested person may request a public hearing. A request for a public hearing must be in writing and must state the nature of the issues proposed to be raised in the hearing. The Agency must consider all comments in making the final decision and must answer, as provided in Section 705.210.

BOARD NOTE: Derived from 40 CFR 124.11 (2017).

(Source: Amended at 42 Ill. Reg. 21179, effective November 19, 2018)

Section 705.182 Public Hearings

- a) When the Agency Holds Public Hearings
 - 1) The Agency must hold a public hearing whenever it finds a significant degree of public interest in a draft permit on the basis of requests.
 - 2) The Agency may also hold a public hearing at its discretion, whenever such a hearing might clarify one or more issues involved in the permit decision.
 - 3) For RCRA permits only the following additional requirements apply:
 - A) The Agency must hold a public hearing whenever it receives written notice of opposition to a draft permit and a request for a hearing within 45 days of public notice under Section 705.162(a);
 - B) Whenever possible, the Agency must schedule the hearing at a location convenient to the population center nearest to the proposed facility.
 - 4) Public notice of the hearing must be given as specified in Section 705.162.
- b) Whenever a public hearing will be held, the Agency must designate a hearing officer who must be responsible for its scheduling and orderly conduct. Conduct of the hearing must be in accordance with Agency rules and procedures, and the hearing must be held in the county in which the HWM or UIC facility or proposed HWM or UIC facility is located.
- c) Any person may submit oral or written statements and data concerning the draft permit. Reasonable limits may be set by the hearing officer on the time allowed at

hearing for oral statements, and the submission of statements in writing may be required. Written statements must be accepted until the close of the public comment period. The public comment period under Subpart D must automatically be extended to a date not later than 30 days after the close of any public hearing under this Section. The hearing officer may also extend the comment period by entering an appropriate order into the record.

- d) A tape recording or written transcript of the hearing must be made available to the public for inspection during regular business hours at the Agency's office in Springfield. Copies of such recording or transcription must be made available on request, upon payment of reasonable costs of duplication pursuant to applicable Agency rules and procedures.

BOARD NOTE: Derived from 40 CFR 124.12 (2017).

(Source: Amended at 42 Ill. Reg. 21179, effective November 19, 2018)

Section 705.183 Obligation to Raise Issues and Provide Information

All persons, including applicants, who believe any condition of a draft permit is inappropriate, or that the Agency's tentative decision to deny an application or prepare a draft permit is inappropriate, must raise all reasonably ascertainable issues and submit all reasonably available arguments and factual grounds supporting their position, including all supporting material, by the close of the public comment period (including any public hearing) under Subpart D. All supporting materials must be included in full and may not be incorporated by reference, unless they are already part of the administrative record in the same proceeding, or they consist of state or federal statutes and regulations, documents of general applicability, or other generally available reference materials. Commenters must make supporting material not already included in the administrative record available to the Agency, as directed by the Agency. The Agency must extend the public comment period by an appropriate time if a commenter demonstrates that the additional time is necessary to submit supporting materials under this Section.

BOARD NOTE: Derived from 40 CFR 124.13 (2017).

(Source: Amended at 42 Ill. Reg. 21179, effective November 19, 2018)

Section 705.184 Reopening of Public Comment Period

- a) The Agency may reopen the public comment period under this Section if doing so could expedite the decisionmaking process.
 - 1) If the public comment period is reopened under this subsection (a), any person, including the applicant, who believes any condition of a draft permit is inappropriate or that the Agency's tentative decision to deny an application or prepare a draft permit is inappropriate, must submit all reasonably available factual grounds supporting their position, including all supporting material, before a date, not less than 60 days after public notice given under subsection (a)(2), set by the Agency. Thereafter, any

person may file a written response to the material filed by any other person, by a date, not less than 20 days after the date set for filing of the material (as set forth in the preceding sentence), set by the Agency.

- 2) Public notice of any comment period under this subsection (a) must identify the issues to which the requirements of this subsection (a) will apply.
 - 3) On its own motion or on the request of any person, the Agency may direct that the requirements of subsection (a)(1) will apply during the initial public comment period where the Agency determines that issuance of the permit will be contested and that applying the requirements of subsection (a)(1) will substantially expedite the decisionmaking process. The notice of the draft permit must state whenever this has been done.
 - 4) A comment period of longer than 60 days may be necessary in complicated proceedings to give commenters a reasonable opportunity to comply with the requirements of this Section. A commenter may request a longer comment period, and one must be granted under Subpart D to the extent that the Agency determines that a longer comment period is necessary.
- b) If any data, information, or arguments submitted during the public comment period appear to raise substantial new questions concerning a permit, the Agency may undertake one or more of the following actions:
- 1) It may prepare a new draft permit, appropriately modified, under Section 705.141;
 - 2) It may prepare a revised statement of basis, a fact sheet, or a revised fact sheet and reopen the comment period under subsection (b)(3);
 - 3) It may reopen or extend the comment period to give interested persons an opportunity to comment on the information or arguments submitted.
- c) Comments filed during the reopened comment period must be limited to the substantial new questions that caused its reopening. The public notice under Subpart D must define the scope of the reopening.
- d) After an extended comment period, the Agency may undertake final action under Section 705.201 that it deems appropriate based on the record.
- e) Public notice of any of the above actions must be issued under Subpart D.

BOARD NOTE: Derived from 40 CFR 124.14 (2017).

(Source: Amended at 42 Ill. Reg. 21179, effective November 19, 2018)

SUBPART F: PERMIT ISSUANCE

Section 705.201 Final Permit Decision

- a) After the close of the public comment period under Subpart D or Section 705.182, the Agency must issue a final permit decision.
- b) A final permit decision must consist of either of the following:
 - 1) A letter of denial that includes each of the following:
 - A) The Sections of the appropriate Act that may be violated if the permit were granted;
 - B) The provisions of Board regulations that may be violated if the permit were granted;
 - C) The specific type of information, if any, that the Agency deems the applicant did not provide with its application; and
 - D) A statement of specific reasons why the Act and the regulations might not be met if the permit were granted; or
 - 2) Issuance of a permit.
- c) On the date of the final permit decision, the Agency must notify the applicant and each person who has submitted written comments or requested notice of the final permit decision. This notice must include reference to the procedures for appealing an Agency RCRA or UIC permit decision under Section 705.212.
- d) A final permit must become effective 35 days after the final permit decision made under subsection (a), unless:
 - 1) A later effective date is specified in the permit; or
 - 2) Review is requested under Section 705.212, in which case the effective date and conditions will be stayed as provided in Sections 705.202 through 705.205.

BOARD NOTE: This Section corresponds with and is partially derived from 40 CFR 124.15 (2017).

(Source: Amended at 42 Ill. Reg. 21179, effective November 19, 2018)

Section 705.202 Stay of Permit Conditions upon Appeal

An appeal pursuant to Section 705.212 has the following effect on permit conditions:

- a) If a timely application was filed for renewal of an existing permit, the existing permit and all its conditions continue to apply during the pendency of the appeal of the renewal permit application, unless the Board orders otherwise.
- b) If an application was filed for renewal of an existing permit after the expiration date of the existing permit, the effect of the new permit and all its conditions are stayed pending the outcome of the appeal, and the facility is without a permit during that time, unless the Board orders otherwise.
- c) If an application was filed for a permit for a new facility, the effect of the new permit and all its conditions are stayed pending the outcome of the appeal.
- d) Contested permit conditions and all permit conditions that are not separable from contested permit conditions are stayed during the pendency of the appeal. The Board may issue an order that identifies the conditions in a permit that are inseparable from contested permit conditions. Where the Board has issued an order that stays some but not all the conditions of a new permit during the pendency of an appeal, compliance is required with those conditions of the existing permit that correspond with the stayed conditions of the new permit, unless compliance with the existing conditions is technologically incompatible with the conditions of the new permit that are not stayed.

BOARD NOTE: Derived from 40 CFR 124.16 (2002).

(Source: Amended at 27 Ill. Reg. 3675, effective February 14, 2003)

Section 705.203 Stay for New Application or upon Untimely Application for Renewal (Repealed)

(Source: Repealed at 27 Ill. Reg. 3675, effective February 14, 2003)

Section 705.204 Stay upon Reapplication or for Modification (Repealed)

(Source: Repealed at 27 Ill. Reg. 3675, effective February 14, 2003)

Section 705.205 Stay Following Interim Status (Repealed)

(Source: Repealed at 27 Ill. Reg. 3675, effective February 14, 2003)

Section 705.210 Agency Response to Comments

- a) At the time that any final permit decision is issued under Section 705.201, the Agency must issue a response to comments. This response must do the following:
 - 1) It must specify which provisions, if any, of the draft permit have been changed in the final permit decision, and the reasons for the change; and

- 2) It must briefly describe and respond to all significant comments on the draft permit raised during the public comment period.
- b) Any documents cited in the response to comments must be included in the administrative record for the final permit decision as defined in Section 705.211. If new points are raised or new material supplied during the public comment period, the Agency may document its response to those matters by adding new materials to the administrative record.
- c) The response to comments must be available to the public in accordance with Agency rules and procedures for access to Agency records.

BOARD NOTE: Derived in part from 40 CFR 124.17 (2002).

(Source: Amended at 27 Ill. Reg. 3675, effective February 14, 2003)

Section 705.211 Administrative Record for Final Permits or Letters of Denial

- a) The Agency must base final permit decisions under Section 705.201 on the administrative record defined in this Section.
- b) The administrative record for any final permit or letter of denial must consist of the administrative record for the draft permit together with the following:
 - 1) All comments received during the public comment period provided under Subpart D (including any extension or reopening under Section 705.184);
 - 2) The tape or transcript of any hearing held under Section 705.182;
 - 3) Any written materials submitted at such a hearing;
 - 4) The response to comments required by Section 705.210 and any new material placed in the record under that Section;
 - 5) Other documents contained in the supporting file for the permit; and
 - 6) The final permit or letter of denial.
- c) The additional documents required under subsection (b) should be added to the record as soon as possible after their receipt or publication by the Agency. The record must be completed on the date that the final permit or letter of denial is issued.
- d) This Section applies to all final RCRA permits, UIC permits, and letters of denial, when the draft permit was subject to the administrative record requirements of Section 705.144.

BOARD NOTE: Derived from 40 CFR 124.18 (2017).

(Source: Amended at 42 Ill. Reg. 21179, effective November 19, 2018)

Section 705.212 Appeal of Agency Permit Determinations

- a) Within 35 days after a RCRA or UIC final permit decision notification has been issued under Section 705.201, the following persons may petition the Board to review any condition of the permit decision:
 - 1) The permit applicant, and
 - 2) Any person who filed comments on the draft permit or who participated in the public hearing on the draft permit.
- b) Any person who failed to file comments or failed to participate in the public hearing on the draft permit may petition for administrative review only to the extent of the changes from the draft to the final permit decision.
- c) A petition for review must include a statement of the reasons supporting that review, including a demonstration that any issues being raised were raised during the public comment period (including any public hearing) to the extent required in this Part; in all other respects, the petition must comport with the requirements for permit appeals generally, as set forth in 35 Ill. Adm. Code 105.
- d) Except as otherwise provided in this Part, the provisions of 35 Ill. Adm. Code 105 generally will govern appeals of RCRA and UIC permits under this Section. References in the procedural rules to the Agency permit application record will mean, for purposes of this Section, the administrative record for the final permit or letter of denial, as defined in Section 705.211.
- e) An appeal under subsection (a) or (b) is a prerequisite to the seeking of judicial review of the final agency action under the administrative review provisions of Article III of the Code of Civil Procedure.

BOARD NOTE: This Section corresponds with 40 CFR 124.19(a) (2017).

(Source: Amended at 42 Ill. Reg. 21179, effective November 19, 2018)

SUBPART G: PROCEDURE FOR RCRA STANDARDIZED PERMIT

Section 705.300 General Information About RCRA Standardized Permits

- a) **RCRA Standardized Permit.** A RCRA standardized permit is a special form of RCRA permit that may consist of two parts: a uniform portion that the Agency issues in all cases, and a supplemental portion that the Agency issues on a case-by-case basis at its discretion. The term “RCRA standardized permit” is defined in 35 Ill. Adm. Code 702.110.

- 1) The Uniform Portion. The uniform portion of a RCRA standardized permit consists of terms and conditions, relevant to the units operated at a facility, that appear in 35 Ill. Adm. Code 727 (Standards for Owners and Operators of Hazardous Waste Facilities Operating under a RCRA Standardized Permit). If an owner or operator intends to operate under the RCRA standardized permit, it must comply with the nationally applicable terms and conditions of 35 Ill. Adm. Code 727.
- 2) The Supplemental Portion. The supplemental portion of a RCRA standardized permit consists of site-specific terms and conditions, beyond those of the uniform portion, that the Agency may impose on a particular facility, as necessary to adequately protect human health and the environment. If the Agency issues a supplemental portion, the owner or operator must comply with the Agency-imposed site-specific terms and conditions.
 - A) When required pursuant to 35 Ill. Adm. Code 727.190(l), provisions to implement corrective action must be included in the supplemental portion.
 - B) Unless otherwise specified, the supplemental permit terms and conditions apply to a facility in addition to the terms and conditions of the uniform portion of the RCRA standardized permit and not in place of any of those terms and conditions.

BOARD NOTE: Subsection (a) is derived from 40 CFR 124.200 (2017).

- b) Eligibility for a RCRA Standardized Permit
 - 1) A facility owner or operator may be eligible for a RCRA standardized permit if it engages in either of the following:
 - A) It generates hazardous waste and then stores or non-thermally treats the hazardous waste on-site in containers, tanks, or containment buildings; or
 - B) It receives hazardous waste generated off-site by a generator under the same ownership as the receiving facility, and then it stores or non-thermally treats the hazardous waste in containers, tanks, or containment buildings.
 - C) In either case, the Agency must inform the owner or operator of its eligibility when a decision is made on its permit.
 - 2) This subsection (b)(2) corresponds with 40 CFR 124.201(b), which USEPA has marked “reserved”. This statement maintains structural consistency with the corresponding federal rule.

BOARD NOTE: Subsection (b) is derived from 40 CFR 124.201 (2017).

(Source: Amended at 42 Ill. Reg. 21179, effective November 19, 2018)

Section 705.301 Applying for a RCRA Standardized Permit

- a) Applying for a RCRA standardized permit.
 - 1) A facility owner or operator must follow the requirements in this Subpart, as well as those in 35 Ill. Adm. Code 703.191 and Subparts B and J of 35 Ill. Adm. Code 703.
 - 2) The owner or operator must submit to the Agency a written Notice of Intent to operate under the RCRA standardized permit. The owner or operator must also include the information and certifications required pursuant to Subpart J of 35 Ill. Adm. Code 703.

BOARD NOTE: Subsection (a) is derived from 40 CFR 124.202, as added at 70 Fed. Reg. 53420 (Sep. 8, 2005).

- b) Switching from an individual RCRA permit to a RCRA standardized permit. Where all units in the RCRA permit are eligible for a RCRA standardized permit, the owner or operator may request that the Agency reissue its individual permit as a RCRA standardized permit. Where only some of the units in the RCRA permit are eligible for the RCRA standardized permit, the owner or operator may request that the Agency modify its individual permit to no longer include those units and issue a RCRA standardized permit for those units. The Agency must modify or reissue any permit in accordance with 35 Ill. Adm. Code 705.128. The Agency must issue any RCRA standardized permit (or reissue a RCRA permit as a RCRA standardized permit) in accordance with Section 705.302(a).

BOARD NOTE: Subsection (b) is derived from 40 CFR 124.203, as added at 70 Fed. Reg. 53420 (Sep. 8, 2005).

(Source: Added at 31 Ill. Reg. 706, effective December 20, 2006)

Section 705.302 Issuance of a RCRA Standardized Permit

- a) Agency Preparation of a Draft RCRA Standardized Permit
 - 1) The Agency must review the Notice of Intent and supporting information submitted by the facility owner or operator.
 - 2) The Agency must determine whether the facility is or is not eligible to operate under the RCRA standardized permit.
 - A) If the facility is eligible for the RCRA standardized permit, the Agency must propose terms and conditions, if any, to include in a

supplemental portion. If the Agency determines that these terms and conditions are necessary to adequately protect human health and the environment, and the terms and conditions cannot be imposed, the Agency must tentatively deny coverage under the RCRA standardized permit.

B) If the facility is not eligible for the RCRA standardized permit, the Agency must tentatively deny coverage under the RCRA standardized permit. Cause for ineligibility may include, but is not limited to, the following:

- i) A failure of owner or operator to submit all the information required pursuant to 35 Ill. Adm. Code 703.351(b).
- ii) Information submitted that is required pursuant to 35 Ill. Adm. Code 703.351(b) that is determined to be inadequate.
- iii) The facility does not meet the eligibility requirements (its activities are outside the scope of the RCRA standardized permit).
- iv) A demonstrated history of significant non-compliance with applicable requirements.
- v) Permit conditions cannot ensure adequate protection of human health and the environment.

3) The Agency must prepare its draft permit decision within 120 days after receiving the Notice of Intent and supporting documents from a facility owner or operator. The Agency's tentative determination pursuant to this Section to deny or grant coverage under the RCRA standardized permit, including any proposed site-specific conditions in a supplemental portion, constitutes a draft permit decision. The Agency is allowed a one time extension of 30 days to prepare the draft permit decision. When the use of the 30-day extension is anticipated, the Agency must inform the permit applicant during the initial 120-day review period. Reasons for an extension may include, but are not limited to, needing to complete review of submissions with the Notice of Intent (*e.g.*, closure plans, waste analysis plans, etc. for facilities seeking to manage hazardous waste generated off-site).

4) Many requirements in this Part and 35 Ill. Adm. Code 702 apply to processing the RCRA standardized permit application and preparing the Agency's draft permit decision. For example, the Agency's draft permit decision must be accompanied by a statement of basis or fact sheet and must be based on the administrative record. In preparing the Agency's draft permit decision, the following provisions of this Part and 35 Ill. Adm. Code 702 apply (subject to the following modifications):

- A) Section 705.101 (Scope and Applicability): all subsections apply.
- B) 35 Ill. Adm. Code 702.110 (Definitions): all definitions apply.
- C) Sections 705.121 (Permit Application) and 705.124 (Site Visit): all subsections apply.
- D) Section 705.127 (Consolidation of Permit Processing): applies.
- E) Section 705.128 (Modification or Reissuance of Permits): does not apply.
- F) Section 705.141 (Draft Permits): does not apply to the RCRA standardized permit; procedures in this Subpart G apply instead.
- G) Section 705.142 (Statement of Basis): applies.
- H) Section 705.143 (Fact Sheet): all subsections apply; however, in the context of the RCRA standardized permit, the reference to the public comment period is Section 705.303(b) instead of Subpart D.
- I) Section 705.144 (Administrative Record for Draft Permits or Notices of Intent to Deny): all subsections apply.
- J) Subpart D (Public Notice): only Section 705.163(a)(4) and (a)(5)(A) applies to the RCRA standardized permit. Most of Subpart D does not apply to the RCRA standardized permit; Section 705.303(a) through (c) applies instead.

BOARD NOTE: Subsection (a) is derived from 40 CFR 124.204 (2017).

- b) Preparation of a Final RCRA Standardized Permit. The Agency must consider all comments received during the public comment period (see Section 705.303(b)) in making its final permit decision. In addition, many requirements in this Part and 35 Ill. Adm. Code 702 apply to the public comment period, public hearings, and preparation of the Agency's final permit decision. In preparing a final permit decision, the following provisions of this Part and 35 Ill. Adm. Code 702 apply (subject to the following modifications):
 - 1) Section 705.101 (Scope and Applicability): all subsections apply.
 - 2) 35 Ill. Adm. Code 702.110 (Definitions): all definitions apply.
 - 3) Section 705.181 (Public Comments and Requests for Public Hearings): Section 705.181 does not apply to the RCRA standardized permit; the procedures in Section 705.303(b) apply instead.

- 4) Section 705.182 (Public Hearings): Section 705.182(b), (c), and (d) applies.
- 5) Section 705.183 (Obligation to Raise Issues and Provide Information): all subsections apply; however, in the context of the RCRA standardized permit, the reference to the public comment period is Section 705.303(b) instead of Subpart D.
- 6) Section 705.184 (Reopening of the Public Comment Period): all of subsections apply; however, in the context of the RCRA standardized permit, the reference in Section 705.184(b)(1) to preparation of a draft permit is Section 705.302(a) instead of Section 705.141; the reference in Section 705.184(b)(3) to reopening or extending the comment period relates to Section 705.303(b); the reference in Section 705.184(c) to the public notice is Section 705.303(a) instead of Subpart D.
- 7) Section 705.201 (Final Permit Decision): all subsections apply; however, in the context of the RCRA standardized permit, the reference to the public comment period is Section 705.303(b) instead of Subpart D.
- 8) Section 705.202 (Stay of Permit Conditions upon Appeal): all subsections apply.
- 9) Section 705.210 (Agency Response to Comments): Section 705.210 does not apply to the RCRA standardized permit; procedures in Section 705.303(c) apply instead.
- 10) Section 705.211 (Administrative Record for Final Permit or Letters of Denial): all subsections apply, however, the reference to response to comments is Section 705.303(c) instead of Section 705.210.
- 11) Section 705.212 (Appeal of Agency Permit Determinations): all subsections apply.
- 12) Section 705.103 (Computation of Time): all subsections apply.

BOARD NOTE: Subsection (b) is derived from 40 CFR 124.205 (2017).

- c) When a facility owner or operator must apply for an individual permit.
 - 1) Instances in which the Agency may determine that a facility is not eligible for the RCRA standardized permit include, but are not limited to, the following:
 - A) The facility does not meet the criteria in Section 705.300(b).
 - B) The facility has a demonstrated history of significant non-compliance with regulations or permit conditions.

- C) The facility has a demonstrated history of submitting incomplete or deficient permit application information.
 - D) The facility has submitted incomplete or inadequate materials with the Notice of Intent (submitted pursuant to Section 705.301(a)(2)).
- 2) If the Agency determines that a facility is not eligible for the RCRA standardized permit, the Agency must inform the facility owner or operator that it must apply for an individual permit.
 - 3) The Agency may require any facility that has a RCRA standardized permit to apply for and obtain an individual RCRA permit. Any interested person may petition the Agency to take action pursuant to this subsection (c)(3). Instances in which the Agency may require an individual RCRA permit include, but are not limited to, the following:
 - A) The facility is not in compliance with the terms and conditions of the standardized RCRA permit.
 - B) Circumstances have changed since the time the facility owner or operator applied for the RCRA standardized permit, so that the facility's hazardous waste management practices are no longer appropriately controlled under the RCRA standardized permit.
 - 4) The Agency may require any facility authorized by a RCRA standardized permit to apply for an individual RCRA permit only if the Agency has notified the facility owner or operator in writing that an individual permit application is required. The Agency must include in this notice a brief statement of the reasons for its decision, a statement setting a deadline for the owner or operator to file the application, and a statement that, on the effective date of the individual RCRA permit, the facility's RCRA standardized permit automatically terminates. The Agency may grant additional time upon request from the facility owner or operator.
 - 5) When the Agency issues an individual RCRA permit to an owner or operator otherwise subject to a standardized RCRA permit, the RCRA standardized permit for that facility will automatically cease to apply on the effective date of the individual permit.

BOARD NOTE: Subsection (c) is derived from 40 CFR 124.206 (2017). An owner or operator authorized to operate under a RCRA standardized permit that is required by the Agency to submit an application for an individual permit pursuant to this subsection (c) may appeal that Agency determination before the Board pursuant to Section 40 of the Act and 35 Ill. Adm. Code 101 and 105.

(Source: Amended at 42 Ill. Reg. 21179, effective November 19, 2018)

Section 705.303 Public Participation in the RCRA Standardized Permit Process

- a) Requirements for Public Notices
 - 1) The Agency must provide public notice of its draft permit decision and must provide an opportunity for the public to submit comments and request a hearing on that decision. The Agency must provide the public notice to the following persons:
 - A) The applicant;
 - B) Any other agency that the Agency knows has issued or is required to issue a RCRA permit for the same facility or activity (including USEPA when the draft permit is prepared by the State);
 - C) Federal and State agencies with jurisdiction over fish, shellfish, and wildlife resources and over coastal zone management plans, the Advisory Council on Historic Preservation, Illinois Historic Preservation Agency, including any affected states;
 - D) Everyone on the facility mailing list developed according to the requirements in Section 705.163(a)(4); and
 - E) Any units of local government having jurisdiction over the area where the facility is proposed to be located and to each State agency having any authority under State law with respect to the construction or operation of the facility.
 - 2) The Agency must issue the public notice according to the following methods:
 - A) Publication in a daily or weekly major local newspaper of general circulation and broadcast over local radio stations;
 - B) In a manner constituting legal notice to the public under State law; and
 - C) Any other method reasonably calculated to give actual notice of the draft permit decision to the persons potentially affected by it, including press releases or any other forum or medium to elicit public participation.
 - 3) The Agency must include the following information in the public notice:
 - A) The name and telephone number of the contact person at the facility.

- B) The name and telephone number of the Agency's contact office, and a mailing address to which people may direct comments, information, opinions, or inquiries.
 - C) An address to which people may write to be put on the facility mailing list.
 - D) The location where people may view and make copies of the draft RCRA standardized permit and the Notice of Intent and supporting documents.
 - E) A brief description of the facility and proposed operations, including the address or a map (for example, a sketched or copied street map) of the facility location on the front page of the notice.
 - F) The date that the facility owner or operator submitted the Notice of Intent and supporting documents.
- 4) At the same time that the Agency issues the public notice pursuant to this Section, it must place the draft RCRA standardized permit (including both the uniform portion and the supplemental portion, if any), the Notice of Intent and supporting documents, and the statement of basis or fact sheet in a location accessible to the public in the vicinity of the facility or at the local Agency office.

BOARD NOTE: Subsection (a) is derived from 40 CFR 124.207 (2017).

- b) Opportunities for Public Comment and Hearing on a Draft Permit Decision
- 1) The public notice that the Agency issues pursuant to Section 705.303(a) must allow at least 45 days for interested persons to submit written comments on its draft permit decision. This time is referred to as the public comment period. The Agency must automatically extend the public comment period to the close of any public hearing pursuant to this subsection (b). The hearing officer may also extend the comment period by so stating at the hearing.
 - 2) During the public comment period, any interested person may submit written comments on the draft permit and may request a public hearing. Any request for a public hearing must be submitted to the Agency in writing. The request for a public hearing must state the nature of the issues that the requestor proposes to raise during the hearing.
 - 3) The Agency must hold a public hearing whenever it receives a written notice of opposition to a RCRA standardized permit and a request for a public hearing within the public comment period pursuant to subsection (b)(1). The Agency may also hold a public hearing at its discretion,

whenever, for instance, such a hearing might clarify one or more issues involved in the permit decision.

- 4) Whenever possible, the Agency must schedule a hearing pursuant to this subsection (b) at a location convenient to the nearest population center to the facility. The Agency must give public notice of the hearing at least 30 days before the date set for the hearing. (The Agency may give the public notice of the hearing at the same time it provides public notice of the draft permit, and the Agency may combine the two notices.)
- 5) The Agency must give public notice of the hearing according to the methods in Section 705.303(a)(1) and (a)(2). The hearing must be conducted according to the procedures in Section 705.182(b), (c), and (d).
- 6) In their written comments and during the public hearing, if held, interested persons may provide comments on the draft permit decision. These comments may include, but are not limited to, the facility's eligibility for the RCRA standardized permit, the tentative supplemental conditions proposed by the Agency, and the need for additional supplemental conditions.

BOARD NOTE: Subsection (b) is derived from 40 CFR 124.208 (2017).

c) Requirements for Responding to Comments

- 1) At the time the Agency issues a final RCRA standardized permit, it must also respond to comments received during the public comment period on the draft permit. The Agency's response must do each of the following:
 - A) It must specify which additional conditions (i.e., those in the supplemental portion), if any, the Agency changed in the final permit, and the reasons for each change.
 - B) It must briefly describe and respond to all significant comments on the facility's ability to meet the general requirements (i.e., those terms and conditions in the uniform portion) and all significant comments on any additional conditions necessary to adequately protect human health and the environment that are raised during the public comment period or during the hearing.
 - C) It must make the comments and responses accessible to the public.
- 2) The Agency may request additional information from the facility owner or operator or inspect the facility if it needs additional information to adequately respond to significant comments or to make decisions about conditions that it may need to add to the supplemental portion of the RCRA standardized permit.

- 3) The Agency must include in the administrative record for its final permit decision any documents cited in the response to comments. If new points are raised or new material supplied during the public comment period, the Agency may document its response to those matters by adding new materials to the administrative record.

BOARD NOTE: Subsection (c) is derived from 40 CFR 124.209 (2017).

- d) Appeal of a Final RCRA Standardized Permit by an Interested Party in the Permit Process. An interested party may petition the Board for administrative review of the Agency's final permit decision, including the Agency's decision that the facility is eligible for the RCRA standardized permit, according to the procedures of Section 705.212. However, the terms and conditions of the uniform portion of the RCRA standardized permit are not subject to administrative review pursuant to this subsection (d).

BOARD NOTE: Subsection (d) is derived from 40 CFR 124.210 (2017).

(Source: Amended at 42 Ill. Reg. 21179, effective November 19, 2018)

Section 705.304 Modifying a RCRA Standardized Permit

- a) Permissible Types of Changes an Owner or Operator May Make to its RCRA Standardized Permit. A facility owner or operator may make a routine change, a routine change with prior Agency approval, or a significant change. For the purposes of this subsection (a), the following definitions apply:

“Routine change” is any change to the RCRA standardized permit that qualifies as a Class 1 permit modification (without prior Agency approval) pursuant to Appendix A to 35 Ill. Adm. Code 703.

“Routine change with prior Agency approval” is a change to the RCRA standardized permit that would qualify as a Class 1 modification with prior agency approval, or a Class 2 permit modification pursuant to Appendix A to 35 Ill. Adm. Code 703.

“Significant change” is any change to the RCRA standardized permit that falls into one of the following categories:

It qualifies as a Class 3 permit modification pursuant to Appendix A to 35 Ill. Adm. Code 703;

It is not explicitly identified in Appendix A to 35 Ill. Adm. Code 703; or

It amends any terms or conditions in the supplemental portion of the RCRA standardized permit.

BOARD NOTE: Subsection (a) is derived from 40 CFR 124.211 (2017).

b) Procedures to Make Routine Changes

- 1) An owner or operator can make routine changes to the RCRA standardized permit without obtaining approval from the Agency. However, the owner or operator must first determine whether the routine change it will make amends the information it submitted to the Agency pursuant to 35 Ill. Adm. Code 703.351(b) with its Notice of Intent to operate under the RCRA standardized permit.
- 2) If the routine changes that the owner or operator makes amend the information it submitted pursuant to 35 Ill. Adm. Code 703.351(b) with its Notice of Intent to operate under the RCRA standardized permit, then before the owner or operator makes the routine changes it must do both of the following:
 - A) It must submit to the Agency the revised information pursuant to 35 Ill. Adm. Code 703.351(b)(1); and
 - B) It must provide notice of the changes to the facility mailing list and to State and local governments in accordance with the procedures in Section 705.163(a)(4) and (a)(5).

BOARD NOTE: Subsection (b) is derived from 40 CFR 124.212 (2017).

c) Procedures for Routine Changes with Prior Agency Approval

- 1) Routine changes to the RCRA standardized permit may only be made with the prior written approval of the Agency.
- 2) The owner or operator must also follow the procedures in subsections (b)(2)(A) and (b)(2)(B).

BOARD NOTE: Subsection (c) is derived from 40 CFR 124.213 (2017).

d) Procedures the Owner or Operator Must Follow to Make Significant Changes

- 1) The owner or operator must first provide notice of and conduct a public meeting.
 - A) Public meeting. The owner or operator must hold a meeting with the public to solicit questions from the community and inform the community of its proposed modifications to its hazardous waste management activities. The owner or operator must post a sign-in sheet or otherwise provide a voluntary opportunity for people attending the meeting to provide their names and addresses.

- B) Public notice. At least 30 days before the owner or operator plans to hold the meeting, it must issue a public notice in accordance with 35 Ill. Adm. Code 703.191(d).
- 2) After holding the public meeting, the owner or operator must submit a modification request to the Agency that provides the following information:
- A) It must describe the exact changes that the owner or operator wants and whether the changes are to information that the owner or operator provided pursuant to 35 Ill. Adm. Code 703.351(b) or to terms and conditions in the supplemental portion of its RCRA standardized permit;
 - B) It must explain why the modification is needed; and
 - C) It must include a summary of the public meeting held pursuant to subsection (d)(1), along with the list of attendees and their addresses and copies of any written comments or materials they submitted at the meeting.
- 3) Once the Agency receives an owner's or operator's modification request, it must make a tentative determination within 120 days to approve or disapprove the request. The Agency is allowed a one time extension of 30 days to prepare the draft permit decision. When the use of the 30-day extension is anticipated, the Agency should inform the permit applicant during the initial 120-day review period.
- 4) After the Agency makes its tentative determination, the procedures in Sections 705.302(b) and 705.303 for processing an initial request for coverage under the RCRA standardized permit apply to making the final determination on the modification request.

BOARD NOTE: Subsection (d) is derived from 40 CFR 124.214 (2017).

(Source: Amended at 42 Ill. Reg. 21179, effective November 19, 2018)

Section 705. Appendix A Procedures for Permit Issuance

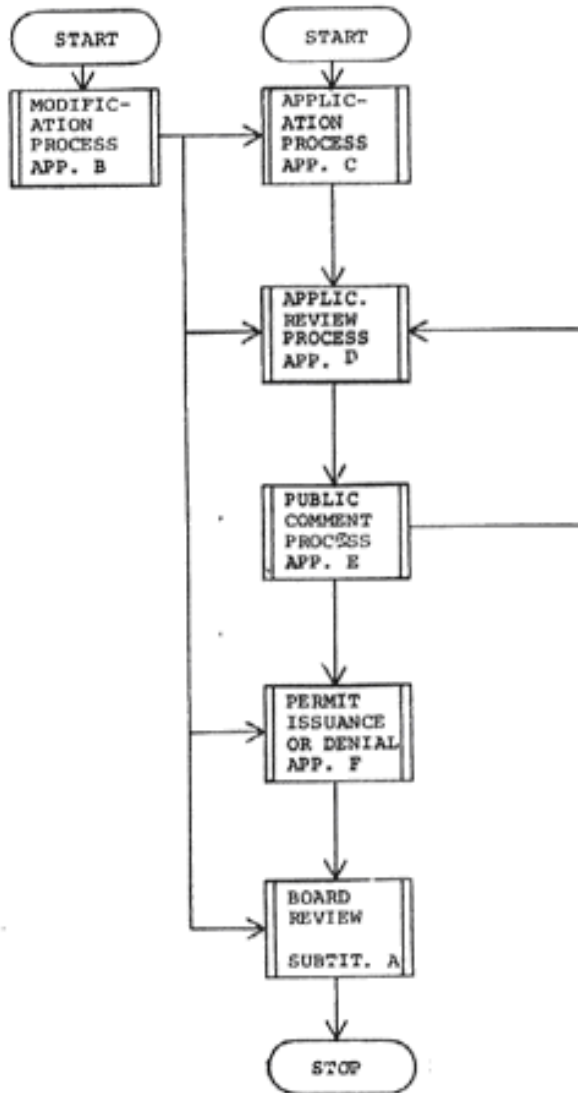

(Source: Amended at 27 Ill. Reg. 3675, effective February 14, 2003)

Section 705. Appendix B Modification Process

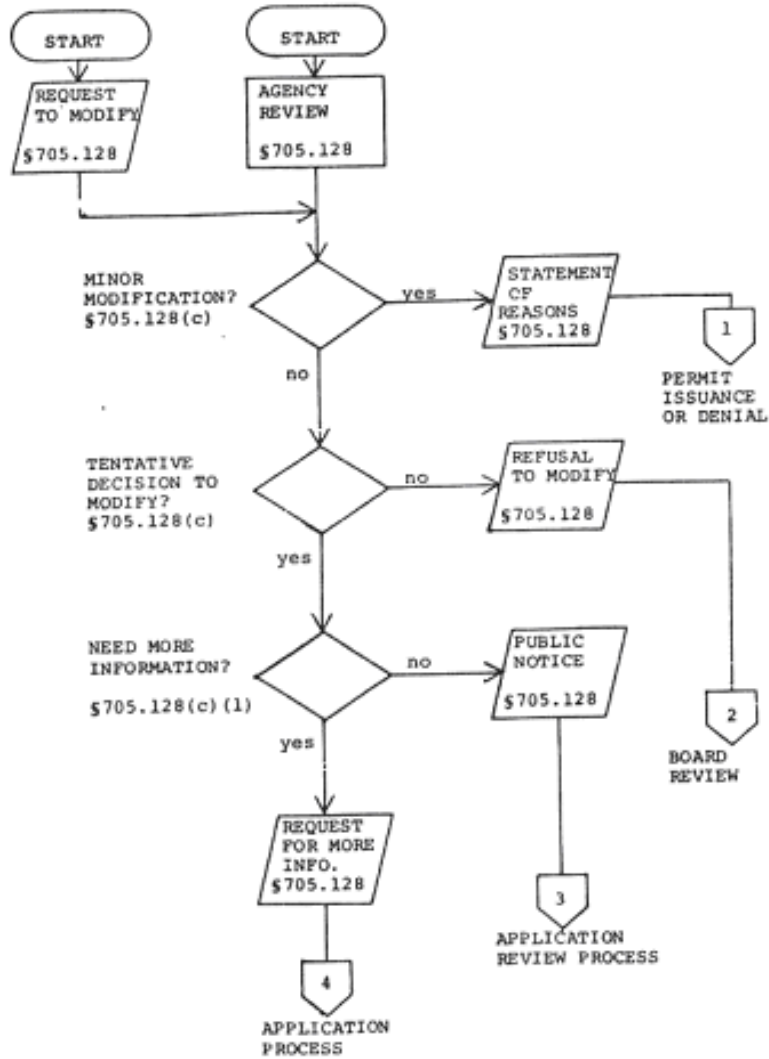

(Source: Amended at 27 Ill. Reg. 3675, effective February 14, 2003)

Section 705.Appendix C Application Process

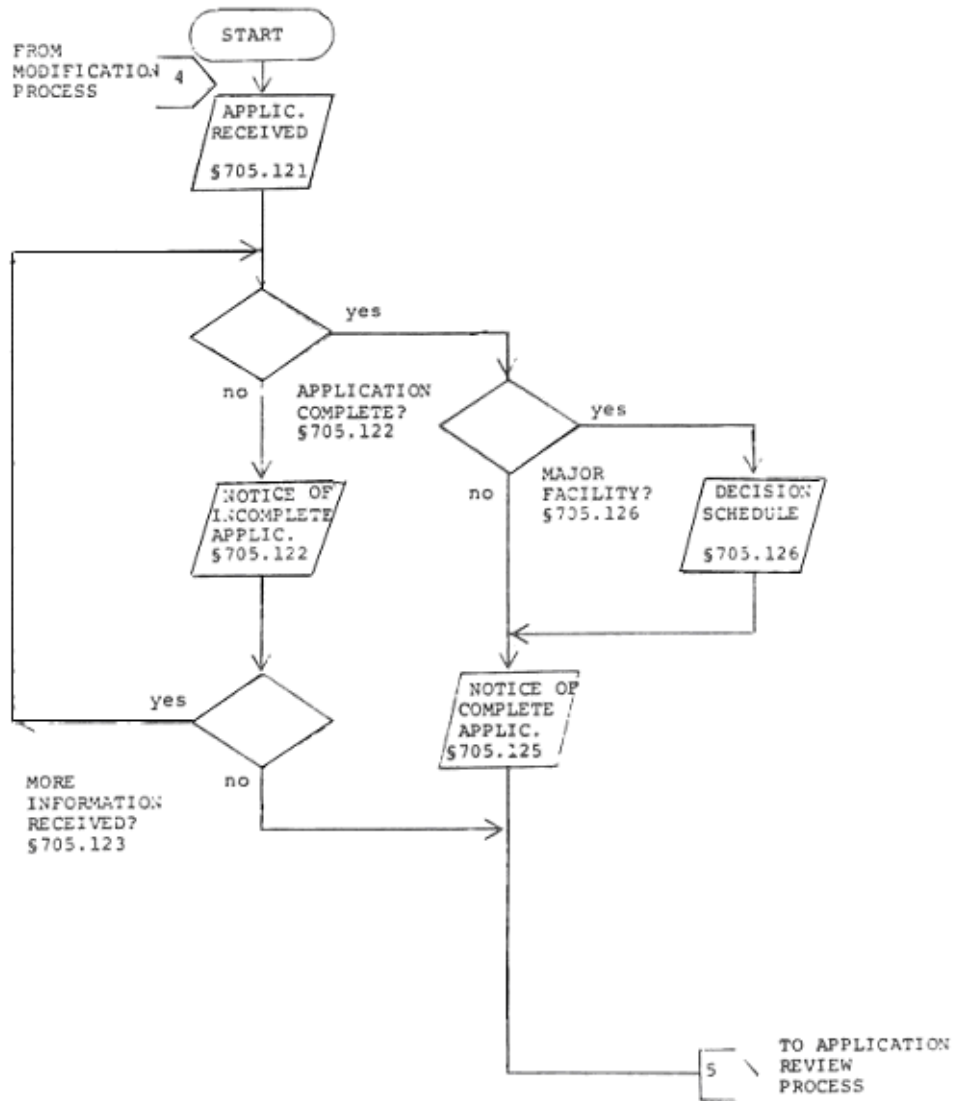

(Source: Amended at 27 Ill. Reg. 3675, effective February 14, 2003)

Section 705. Appendix D Application Review Process

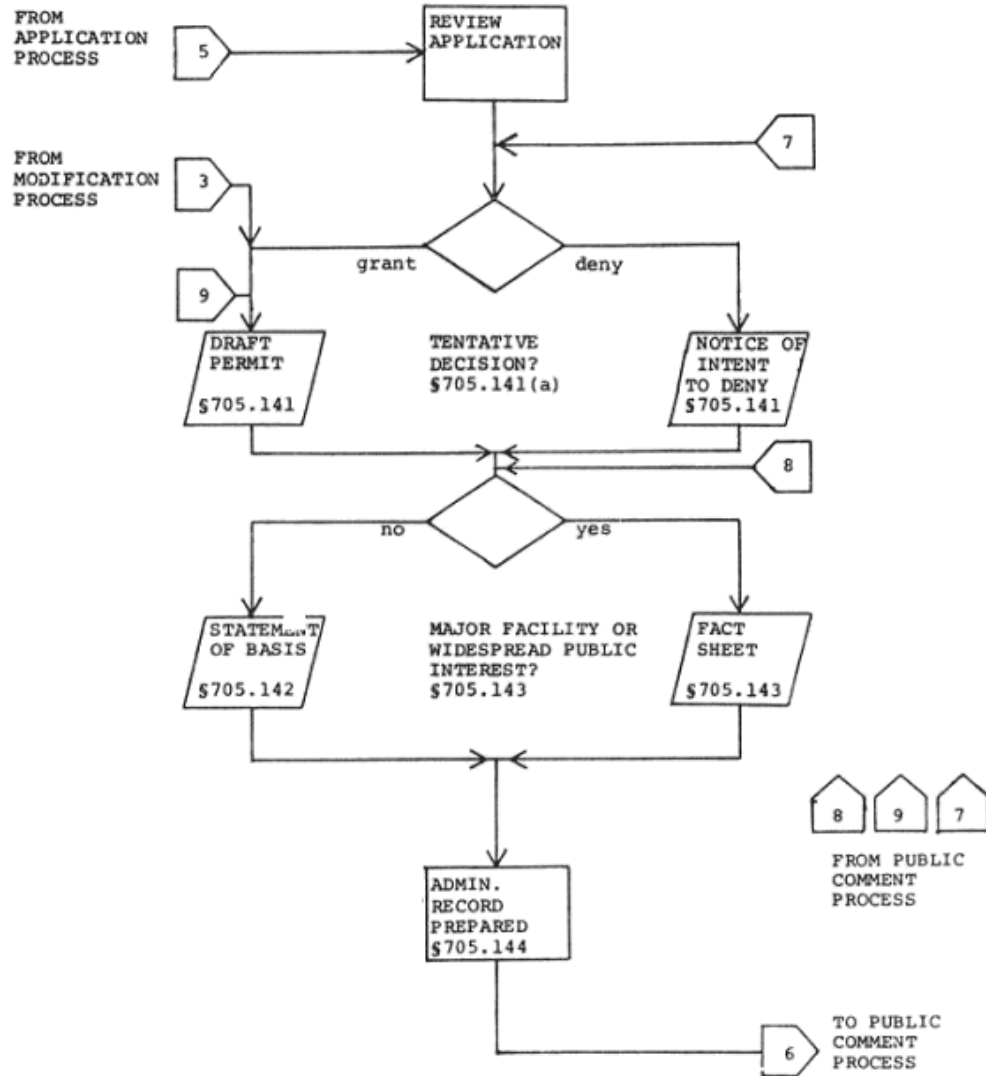

(Source: Amended at 27 Ill. Reg. 3675, effective February 14, 2003)

Section 705. Appendix E Public Comment Process

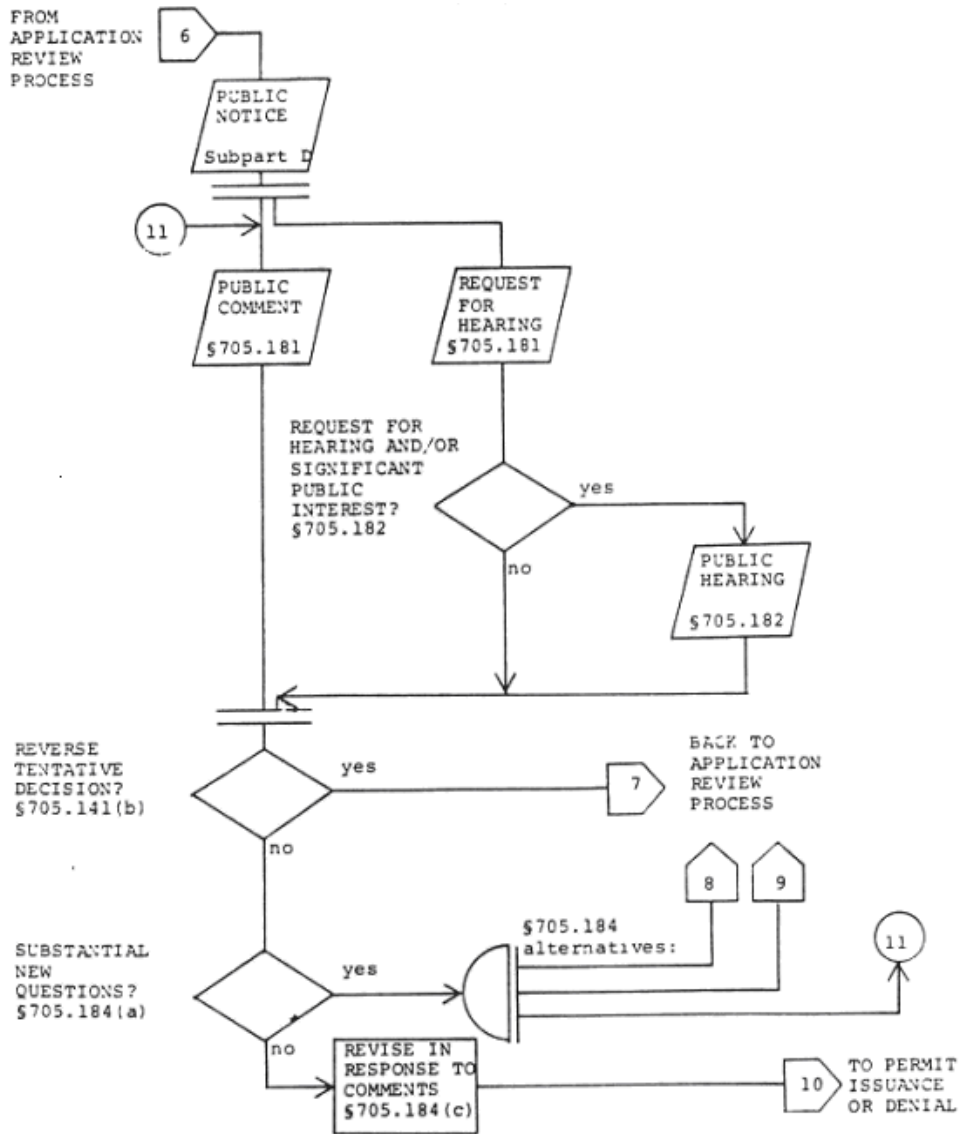

(Source: Amended at 27 Ill. Reg. 3675, effective February 14, 2003)

Section 705. Appendix F Permit Issuance or Denial

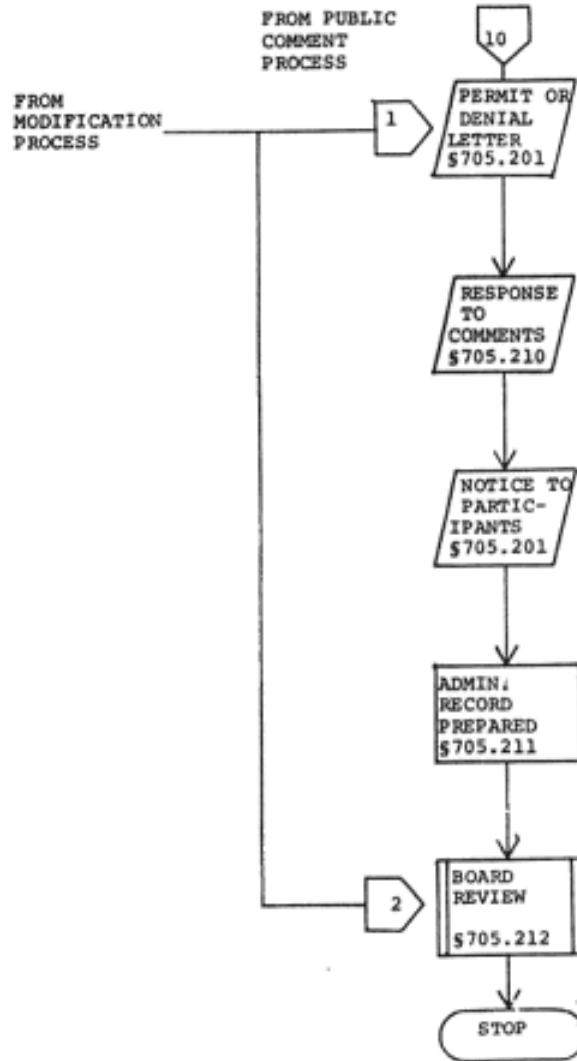

(Source: Amended at 27 Ill. Reg. 3675, effective February 14, 2003)